

Water Brake Engine Dynamometers - H36-Series

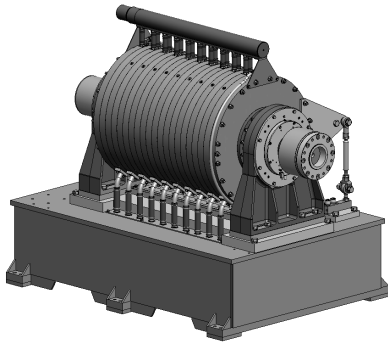

H3610 Water Brake Engine Dynamometer Shown

Overview

Power Test H36-Series Water Brake Engine Dynamometers are designed for testing high torque, low speed diesel engines in the mining, marine, construction, power generation and marine propulsion industries. Application power ranges through 10,000 HP (7,457 Kw) at speeds up to 2,500 RPM and torque up to 50,000 Lb-ft. (67,791 NM).

The H36-Series Water Brake Engine Dynamometers feature:

- The ability to test a wide range of engine displacements on the same dynamometer.
- Low-inertia and high absorption characteristics in a compact package
- Includes torque sensor with linkage and speed sensor with gear assembly.
- Through-shaft design allows either end of the dynamometer to be driven or to accept tandem dynamometers plus a variety of accessories including starting systems
- Includes DIN 315 or 350 (model dependant) series drive shaft companion flange.
- Low minimum loading characteristics
- Fabricated steel Sub-base with 42" (1067 mm) dynamometer centerline (other centerline heights available upon request).
- Water drainage integral into sub-base with your choice of side or rear water discharge.
- Provides bidirectional equal absorption capabilities.

These trunnion-mounted, fixed-base Water Brake Engine Dynamometers may be used for continuous-duty engine power verification, quality assurance, endurance, and certification testing.

Water Brake Engine Dynamometers - H36-Series

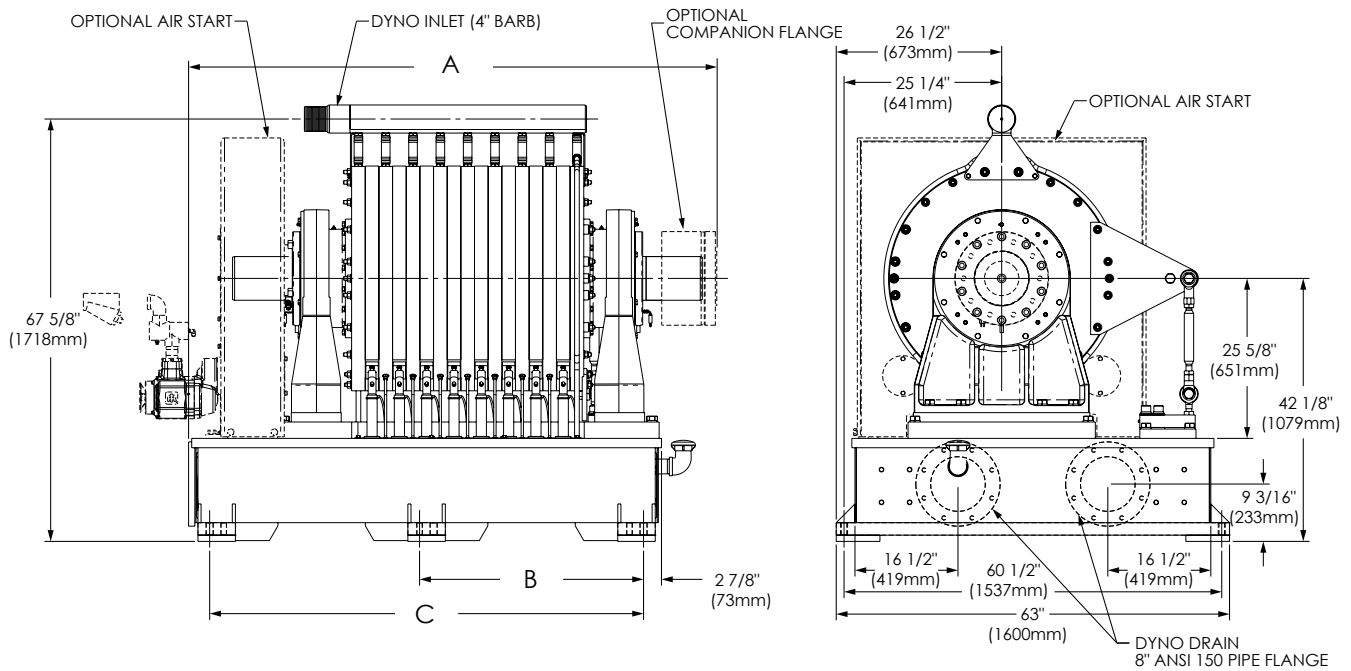

Note

Dimensions are based on a 42" (1067 mm) dynamometer centerline height, some dimensions change if a unique centerline height (available upon request) is ordered.

Description	Part #	Dimensions - inches (mm)			Weight lbs (kg)	Companion Flange	Inertia (lb-ft ²)
		A	B	C			
H3602 Water Brake	1028704.02	58 7/16 (1484)	21 5/8 (549)	43 1/4 (1098)	8,750 (3969)	DIN 315	411
H3604 Water Brake	1028704.04	67 3/16 (1707)	26 (660)	52 (1321)	10,500 (4763)	DIN 315	799
H3606 Water Brake	1028704.06	75 15/16 (1929)	31 1/2 (800)	60 3/4 (1543)	12,250 (5557)	DIN 315	1,187
H3608 Water Brake	1028704.08	84 11/16 (2152)	35 7/8 (911)	69 1/2 (1765)	14,000 (6350)	DIN 350	1,575
H3610 Water Brake	1028704.10	93 7/16 (2373)	40 1/4 (1022)	78 1/4 (1987)	15,750 (7144)	DIN 350	1,963
H3610M Water Brake	1025752.10	93 7/16 (2373)	40 1/4 (1022)	78 1/4 (1987)	15,750 (7144)	DIN 350	1,963



N60 W22700 Silver Spring Drive • Sussex, WI 53089 USA
 phone: (262) 252-4301 • fax: (262) 246-0436
www.powertestdyno.com

Water Brake Engine Dynamometers - H36-Series

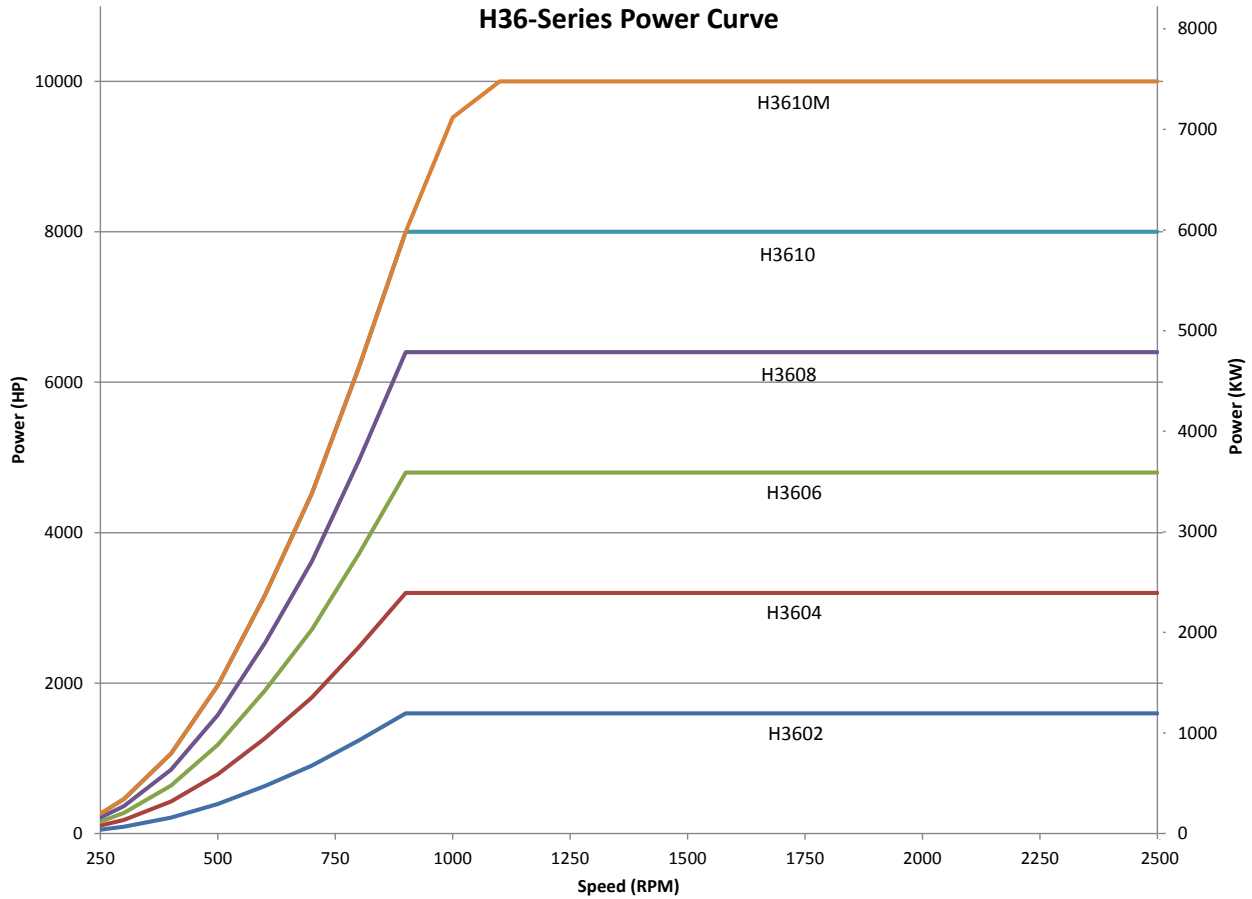

Power - HP (KW)						
RPM	H3602	H3604	H3606	H3608	H3610	H3610M
250	53 (40)	106 (79)	159 (119)	212 (158)	265 (198)	265 (198)
400	213 (159)	426 (318)	638 (476)	851 (635)	1,064 (794)	1,064 (794)
600	633 (472)	1,267 (945)	1,900 (1,417)	2,533 (1,890)	3,166 (2,362)	3,166 (2,362)
900	1,600 (1,194)	3,200 (2,387)	4,800 (3,581)	6,400 (4,774)	8,000 (5,968)	8,000 (5,968)
1,000	1,600 (1,194)	3,200 (2,387)	4,800 (3,581)	6,400 (4,774)	8,000 (5,968)	9,520 (7,102)
1,200	1,600 (1,194)	3,200 (2,387)	4,800 (3,581)	6,400 (4,774)	8,000 (5,968)	10,000 (7,457)
1,700	1,600 (1,194)	3,200 (2,387)	4,800 (3,581)	6,400 (4,774)	8,000 (5,968)	10,000 (7,457)
2,000	1,600 (1,194)	3,200 (2,387)	4,800 (3,581)	6,400 (4,774)	8,000 (5,968)	10,000 (7,457)
2,500	1,600 (1,194)	3,200 (2,387)	4,800 (3,581)	6,400 (4,774)	8,000 (5,968)	10,000 (7,457)



N60 W22700 Silver Spring Drive • Sussex, WI 53089 USA
 phone: (262) 252-4301 • fax: (262) 246-0436
www.powertestdyno.com

Water Brake Engine Dynamometers - H36-Series

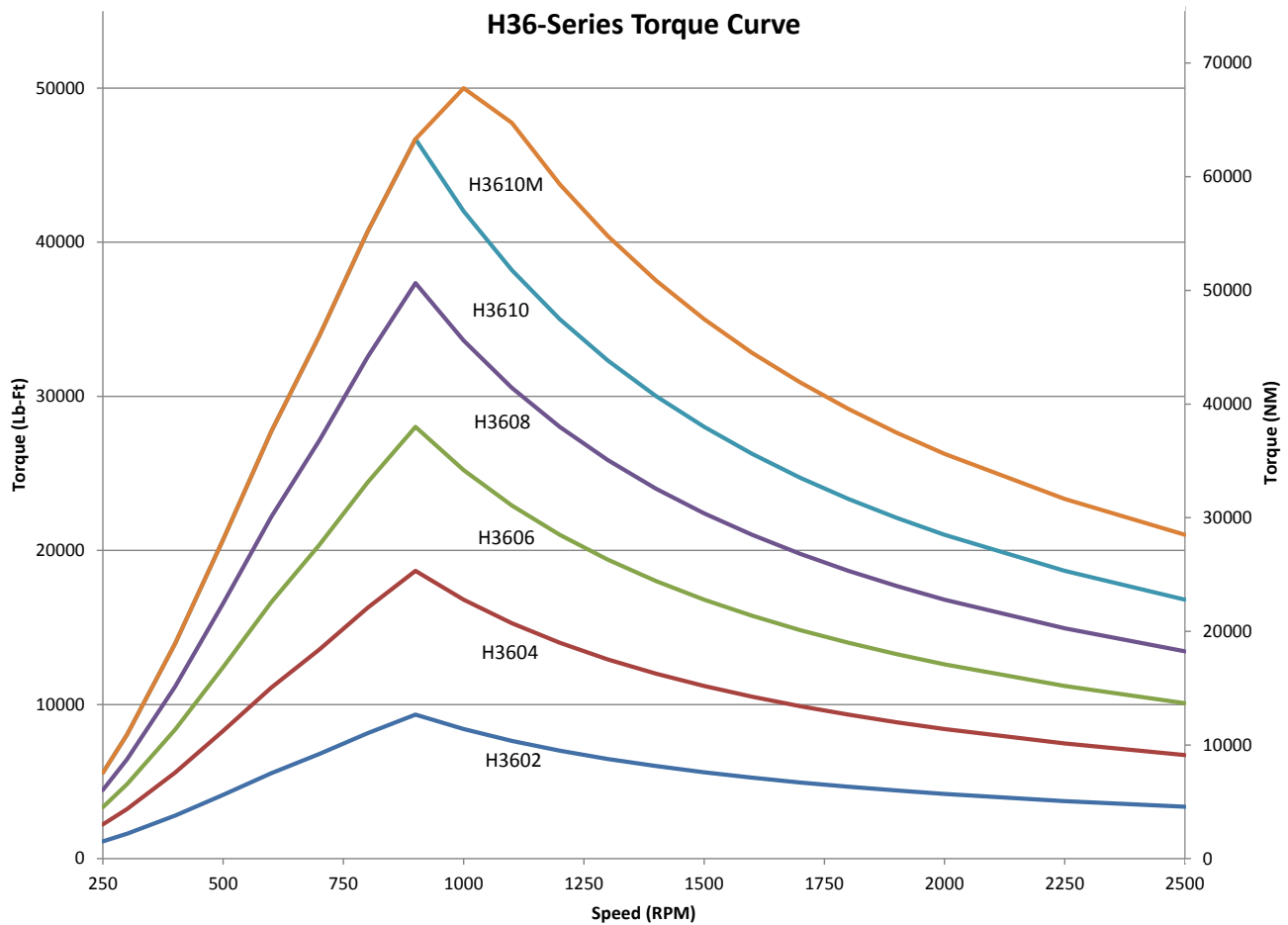

Torque - Lb-Ft (NM)						
RPM	H3602	H3604	H3606	H3608	H3610	H3610M
250	1,113 (1,510)	2,227 (3,020)	3,340 (4,531)	4,454 (6,041)	5,567 (7,551)	5,567 (7,551)
400	2,797 (3,793)	5,593 (7,587)	8,377 (11,362)	11,174 (15,156)	13,970 (18,949)	13,970 (18,949)
600	5,541 (7,516)	11,090 (15,043)	16,631 (22,559)	22,172 (30,074)	27,713 (37,590)	27,713 (37,590)
900	9,337 (12,664)	18,674 (25,329)	28,011 (37,993)	37,348 (50,658)	46,684 (63,322)	46,684 (63,322)
1,000	8,403 (11,398)	16,806 (22,796)	25,210 (34,194)	33,613 (45,592)	41,016 (56,990)	50,000 (67,791)
1,200	7,003 (9,498)	14,005 (18,997)	21,008 (28,495)	28,011 (37,993)	35,013 (47,492)	43,767 (59,365)
1,700	4,943 (6,705)	9,886 (13,409)	14,829 (20,114)	19,772 (26,819)	24,715 (33,524)	30,894 (41,905)
2,000	4,202 (5,699)	8,403 (11,398)	12,605 (17,097)	16,806 (22,796)	21,008 (28,495)	26,260 (35,619)
2,500	3,361 (4,559)	6,723 (9,118)	10,084 (13,678)	13,445 (18,237)	16,806 (22,796)	21,008 (28,495)

Power Test, Inc. manufactures a wide range of standard and custom water brake engine dynamometers. For absorption characteristics other than the model shown, please contact your Power Test representative.



N60 W22700 Silver Spring Drive • Sussex, WI 53089 USA
 phone: (262) 252-4301 • fax: (262) 246-0436
www.powertestdyno.com