

Actual products may differ
from images shown

Specifications:

Power:	1,500 hp (1,119 kW)
Max Torque at Base Speed:	8,517 lb-ft (11,547 Nm)
Base Speed:	925 rpm
Max. Speed:	3,600 rpm
Construction Type:	Wet Gap
Rotor Inertia:	698 lb-ft ² (29.41 kg-m ²)
Coolant Required at Max. Power:	150 gpm (567.8 lpm)
Coolant Inlet (Min-Max):	55-100 psi (378-689 kPa)
Coolant Inlet Temperature Max:	90°F (32.2°C)
Shipping Weight (estimate):	10,500 lb (4,763 kg)
Companion Flange / Hub Pattern:	1910 - US Customary
Coil Voltage / Hot Amperage:	220V / 8.2 amps
Rotation:	bi-directional

For overhung loads, such as a belt or gear drive, please contact us to ensure that the system will meet the required performance needs

Recommended Accessories:

- Driveshaft - 1910
- Torsional Coupling - 1910
- Flywheel Adapter Plate Kit
- Driveshaft Guard
- Sub-Base Kit
- Engine Cart
- Air or Electric Starter
- Engine Cooling Column
- Charge Air Cooler
- Water Recirculating System

E-2025-W138 (US Customary)

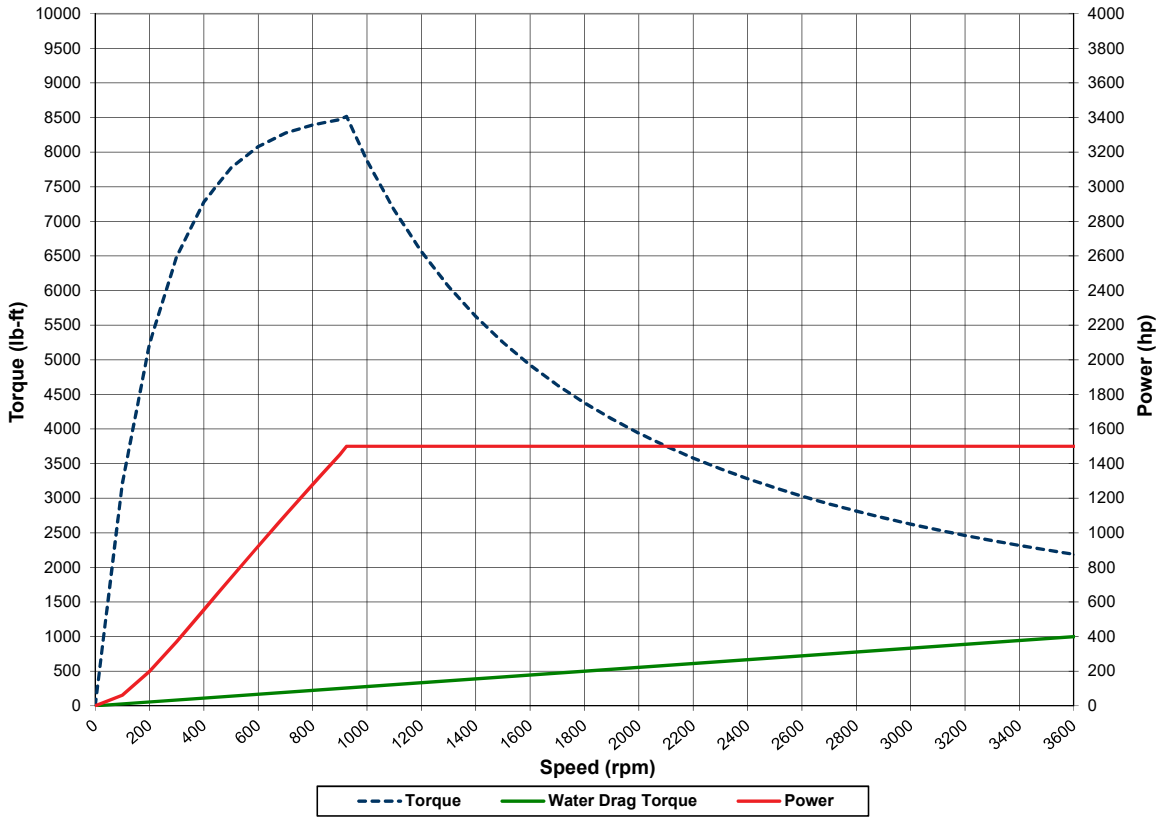

E-2025-W138 (S.I.)

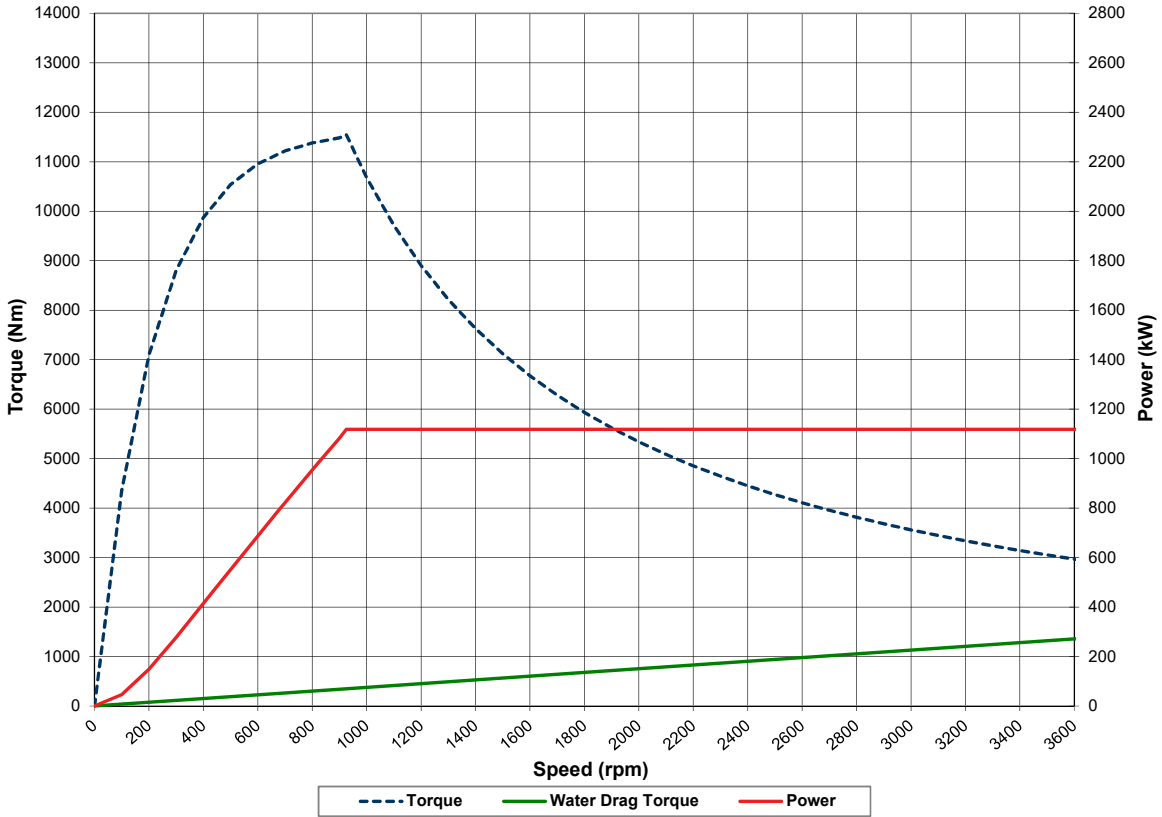

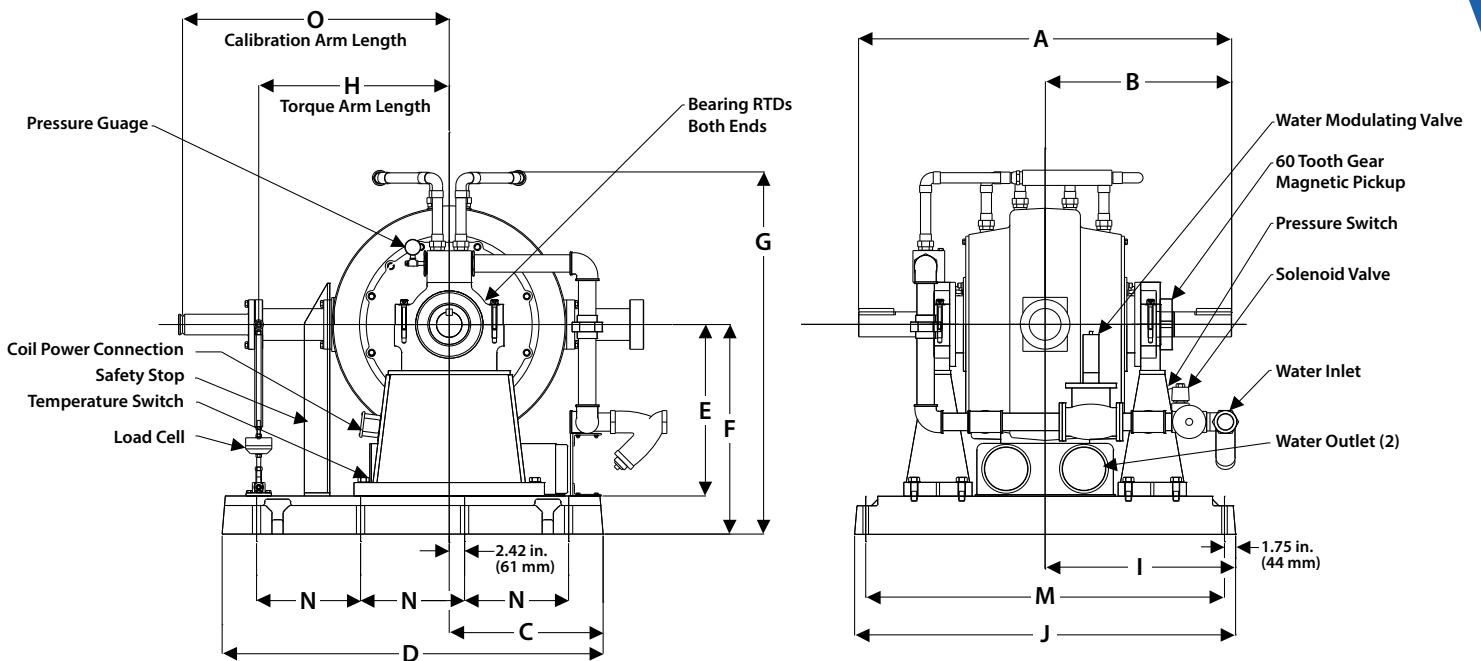

Note: Shown without companion flange

Units	A	B	C	D	E	F	G	H	I
US Customary	57	28.5	24.24	60	27	38	62	30	30
S.I.	1,448	724	616	1,524	686	965	1,575	762	762

Units	J	M	N	O
US Customary	60	56.5	16.38	42
S.I.	1,524	1,435	416	1,067

(All dimensions are for new OEM supplied units)

As a safety precaution, we recommend a torsional analysis to uncover any potential torsional problems that exist for each application. This analysis will identify any torsional issues (frequencies) that should be fixed prior to operation. Excessive linear vibration may also create problems that must be mitigated for continued operation. It is the customer's responsibility to ensure that these vibration issues are addressed upon application of the dynamometer. Equipment failures attributed to linear or torsional vibration are not warrantable.

Power Test®, LLC, an industry leader in the design, manufacture and sales of dynamometers, specialized test systems, and related data acquisition and control systems. Power Test, LLC, offers a comprehensive portfolio of brands including Power Test, Taylor Dyno™, Dyne Systems™, SuperFlow®, Axiline® Precision Products, Hicklin® Engineering, Stuska® Dynamometer, and Torque Converter Rebuilding Systems (TCRS™), that have long been the standard for quality in the testing industry. As your equipment testing partner for innovative products and comprehensive life-cycle services and support, we are dedicated to delivering an exceptional experience by offering specialized solutions to Make Your Testing Easy.