

XYZ Lift Table for Electric Motors - Medium 150 - 300 hp Tables and Test Stands

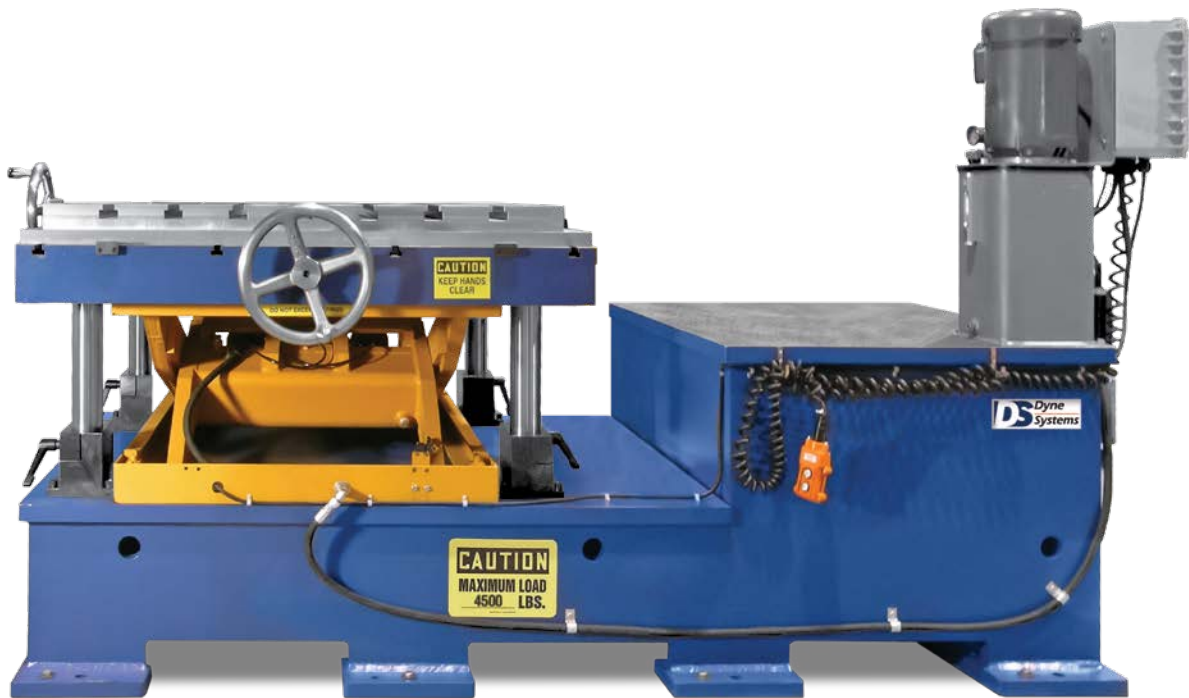

The XYZ Lift Table Test Stand allows the testing of electrical motors with varied horizontal or vertical center lines. It features a fixture mounting plate that can be adjusted on the X-Y-Z axes. The X and Z axes are controlled through manual crank handles while the Y axis is adjusted through a remote pendant which controls a hydraulic scissors lift.

Specifications

- Accommodates dynamometers from 150 - 300 hp (112 - 224 kW)
- Fixture mounting plate can be adjusted on the X-Y-Z axes
- X and Z axes are controlled through manual crank handles
- Y axis is adjusted through a remote pendant which controls a hydraulic scissors lift
- Four stabilizing risers included

Maximum Travel of X axis:	4 in. (102 mm)
Maximum Travel of Z axis:	5 in. (127 mm)
Maximum Travel of Y axis:	12 in. (305 mm)
Maximum Lift Weight:	4,500 lb (2,041 kg)
Mounting Plate Surface Dimensions:	48 x 48 in. (1,219 x 1,219 mm)
Footprint of Unit:	101.6 x 52 in. (2,581 x 1,321 mm)
Weight of Unit:	11,400 lb (5,171 kg)
Power Requirements:	230 VAC / 460 VAC / 3PH / 60Hz @ ~15.0 amp / 7.5 amp

in.
(mm)

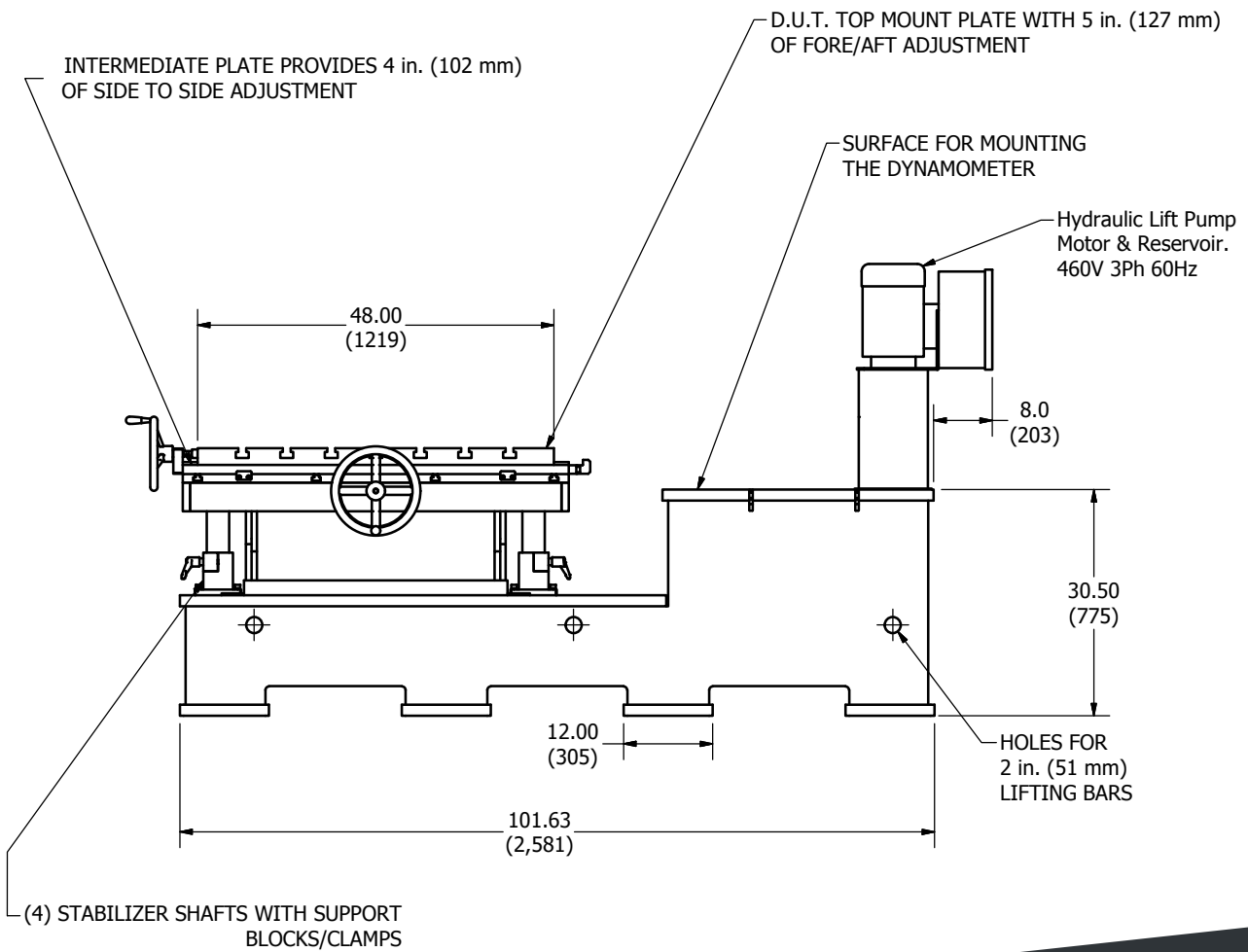
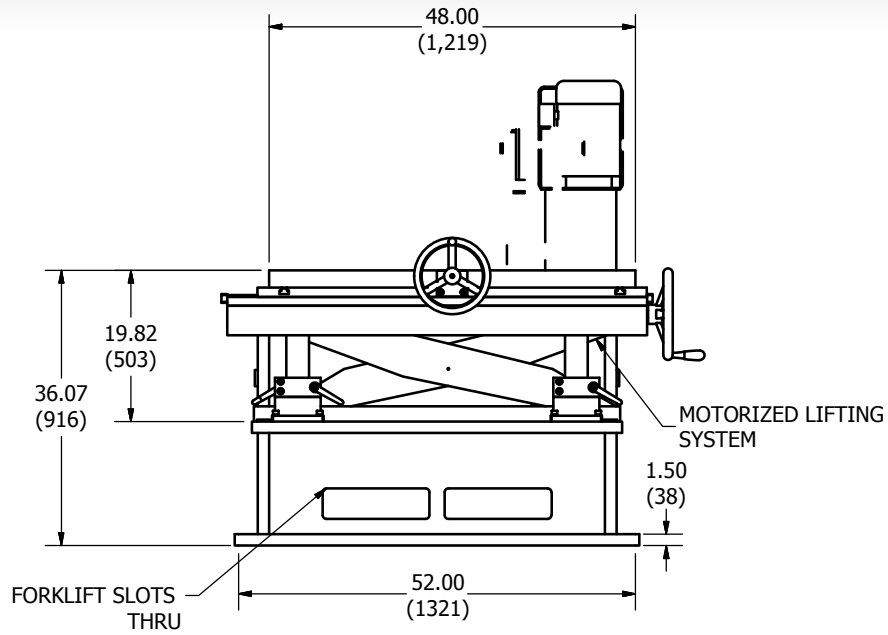

Everything you need to succeed



Dyne Systems is a division of Taylor Dynamometer
(414) 755-0040 www.dynesystems.com

DS9504v002