

Oil Preheat and Supply Cart

Overview

The Power Test Oil Preheat and Supply Cart provides a ready 60 gallon supply of filtered, preheated oil. The supply cart can be used to fill and/or drain oil from transmissions.

Oil Preheat and Supply Cart:

- Rugged design for use in the test cell with direct access to controls.
- Easy to operate and maintain.
- Includes an 11 micron filter.
- Oil pumping rate is 3.3 GPM.

With its added mobility, the Oil Preheat and Supply Cart can be used in multiple test cells.

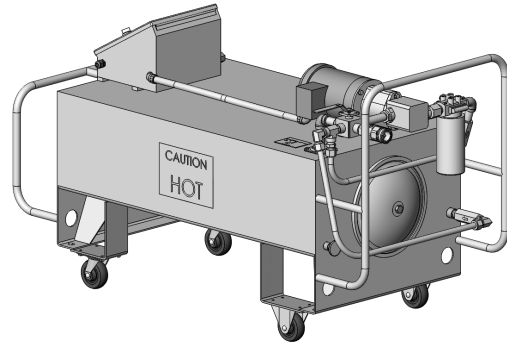

DK0008 Oil Preheat and Supply Cart shown

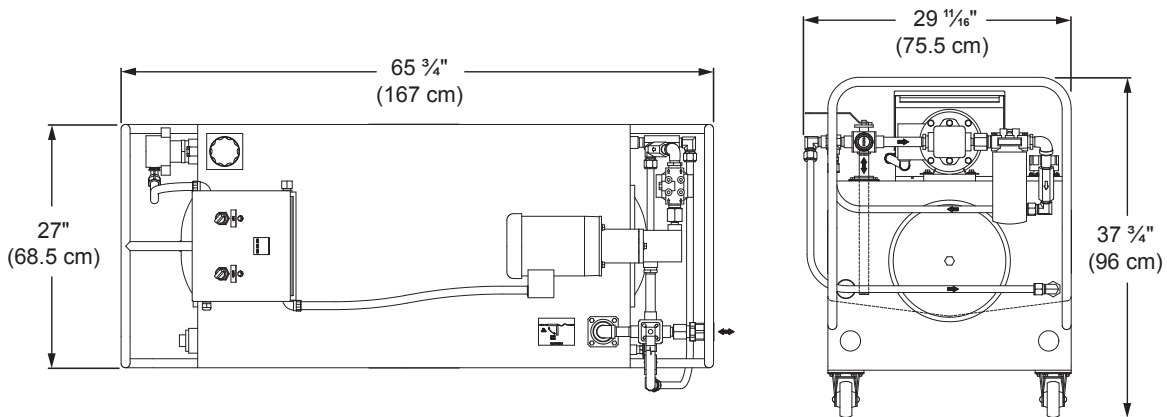

Description	Part #	Electrical Requirements		Empty Weight (lbs)
		Amperage (Amps)	Voltage	
Oil Preheat and Supply Cart	DK0008	30	480 VAC, 60 Hz, 3 Phase	522



N60 W22700 Silver Spring Drive • Sussex, WI 53089 USA
 phone: (262) 252-4301 • fax: (262) 246-0436
www.powertestdyno.com