

# Stall Brake Add-On - 535604

## Overview

The Stall Brake Add-On uses an air actuated brake assembly installed into the Eddy Current Load unit to stall the transmission output using straightforward controls.

### Stall Brake Add-On:

- Allows for automated stall testing when used in conjunction with the PowerNet-TD Data Acquisition and Control system.
- Utilizes the required 80 PSI air supply on model 450E's.
- Can be included with Eddy's on all test stands.
- Provides a safer stall test operation by eliminating the installation of the manual stall bar.
- Max. Stall Torque:  
 w/ Stall Bar: 2,000 Lb-ft. (2,712 N-m)  
 w/ Air Brake: 3,000 Lb-ft. (4,067 N-m)

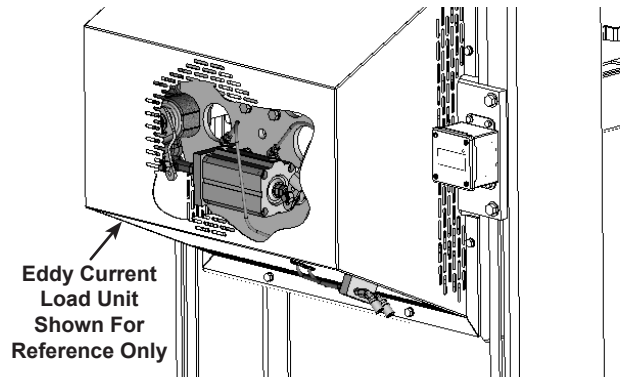

535604 - Stall Brake Kit Add-On For Eddy Current Load Units shown

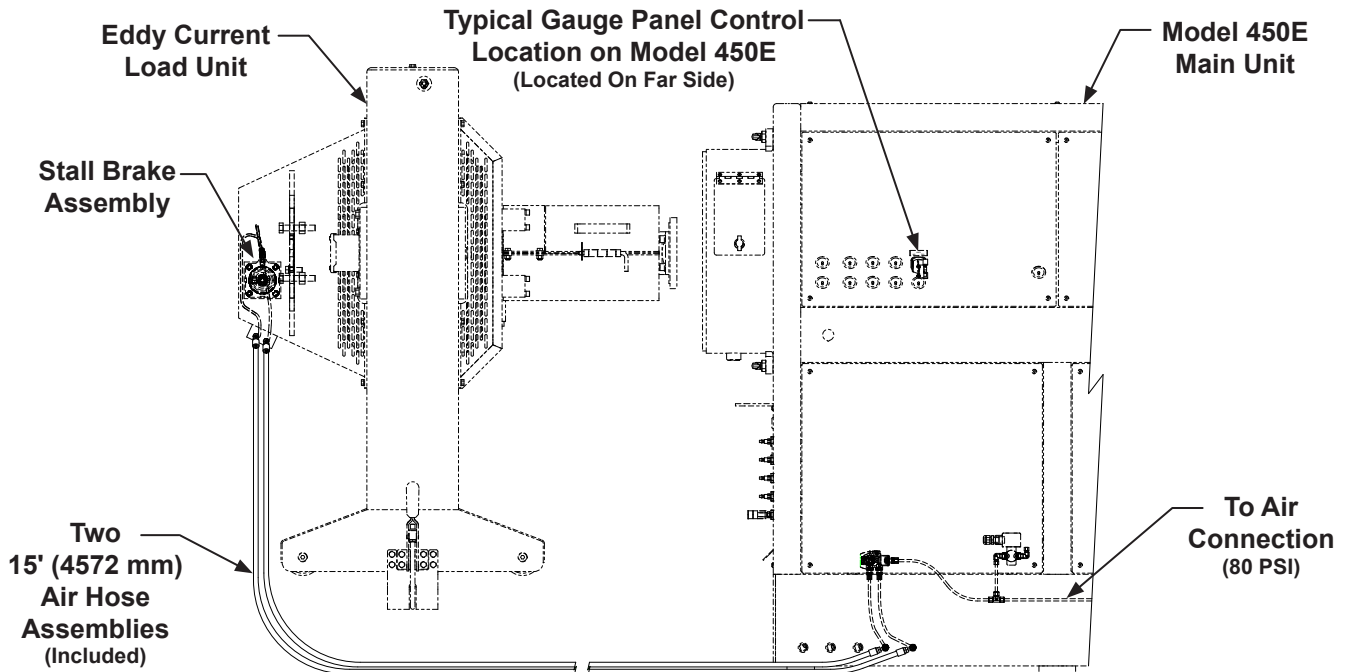

Description	Part #
Stall Brake Add-On - Air (Eddy Trolley)	535604



N60 W22700 Silver Spring Drive • Sussex, WI 53089 USA  
 phone: (262) 252-4301 • fax: (262) 246-0436  
[www.powertestdyno.com](http://www.powertestdyno.com)